

WALKER

Illustrated Parts Manual

H24d



Beginning S/N: 190455
P/N 2000-51

KEY TO ABBREVIATIONS USED IN THIS MANUAL

<i>Abbreviation</i>	<i>What it Represents</i>
° (Dimension)	Degrees (Angle)
" (Dimension)	inches
(-)	Negative (Polarity)
(+)	Positive (Polarity)
-1 (as deck style designation)	Standard (Aluminum) Gear Drive Deck
-2 (as deck style designation)	Heavy Duty (Cast Iron) Gear Drive Deck
-3 (as deck style designation)	Belt Drive Deck
AT	All-Terrain
CCW	Counter-clockwise
CW	Clockwise
D	Diameter
DC	Deck, Collection (number refers to size in inches)
DM	Deck, Mulching (number refers to size in inches)
DR	Deck, Rear Discharge (number refers to size in inches)
DS	Deck, Side Discharge (number refers to size in inches)
DU	Garlock (Bearing)
ESNA (Fastener)	Nylon Insert Locknut
FSC	Forward Speed Control
GA	Gauge
gal.	gallon
GR (Fastener)	Grade
HD	Heavy Duty
HP	Horse Power
ID	Identification or Inside Diameter
L	Length
LH	Left Hand (orientated with operator on seat)
LP	Low Profile
mm (Dimension)	millimeters
MS (Fastener)	Machine Screw
NS (as part number)	Item is not sold by Walker Manufacturing
OD	Outside Diameter
oz.	ounce
PFH (Fastener)	Phillips Flat Head
P/N	Part Number
PPH (Fastener)	Phillips Pan Head
PTH (Fastener)	Phillips Truss Head
PTO	Power Take-Off
QKS	Quick Slide
qt.	quart
RH	Right Hand (orientated with operator on seat)
ROPS	Roll-Over Protection System
SAE (Fastener)	Society of Automotive Engineers
SBH (Fastener)	Socket Button Head (Bolt)
SFH (Fastener)	Slotted Flat Head
SHC (Fastener)	Socket Head Cap
SHL (Fastener)	Shoulder (Bolt)
SM (Fastener)	Sheet Metal (Screw)
S/N	Serial Number
SQH (Fastener)	Square Head
SS (Fastener)	Stainless Steel
ST (Fastener)	Self-Tapping (Screw)
V	Volts
VLR	Very Low Restriction

NOTE: In some instances, combinations of abbreviations may be used (e.g. PPHMS - Phillips Pan Head Machine Screw).

ILLUSTRATED PARTS LIST

<i>Section of Tractor Covered</i>	<i>Page</i>	<i>Section of Tractor Covered</i>	<i>Page</i>
<hr/>		<hr/>	
Decals		Electrical Components	
Tractor Decals	2	Electrical Assembly	20
Body / Chassis Assemblies		Maintenance	
Body Assembly	4	Lubrication Points	22
Chassis Assembly	6	Caster Wheel Fork Installation	24
Tractor Components		Wiring Schematic	25
Main Component Power Transmission	8	Electrical Assembly (Connections)	26
Engine Group	10	Maintenance And Service Record Sheet	27
Radiator Group	12	Warranty	
Hydrostatic Ground Drive Assemblies	14	Limited Warranty	29
Steering Control Assemblies	16		
Roll-Over Protection System (ROPS)	18		

TRACTOR DECALS

ITEM NO.	PART NO.	DESCRIPTION	LOCATION	NO. REQ'D SD
Walker Product and Operation Decals				
1	2802-4	RH Fender	Body, RH near Seat	1
2	2010-17	Fuel Transfer	Transfer Mount, RH	1
3	5800-9	Decal, Walker Round (4-3/4")	Rear Body (one on each side)	2
4	2802-5	LH Fender	Body, LH near Seat	1
5	9804-1	Axle Lockout	Hydro Mount Plate	2
6	8821-6	Decal, H24d	Body	1
7	5856-1	Made in USA	Body	1
Danger Decals Warning Decals Caution Decals				
8	5685-3	Decal, ROPS	ROPS	1
9	8600-12	Danger, Engine Exhaust	Engine Brace	1
10	2107-5	Decal, Belt Routing	Rear Body, Underside	1
11	8600-2	Danger, Rotating Components	Coupling Guard	1
Maintenance Decals				
12	2427-9	Radiator Solution	Radiator	1
13	2807-9	Decal, Amp/Glow Plug	Body	1
14	6875	PTO Alignment Arrow	Universal Joint Tube Assembly	1

NOTE: All parts requiring decals are shipped with decals applied.

TRACTOR DECALS

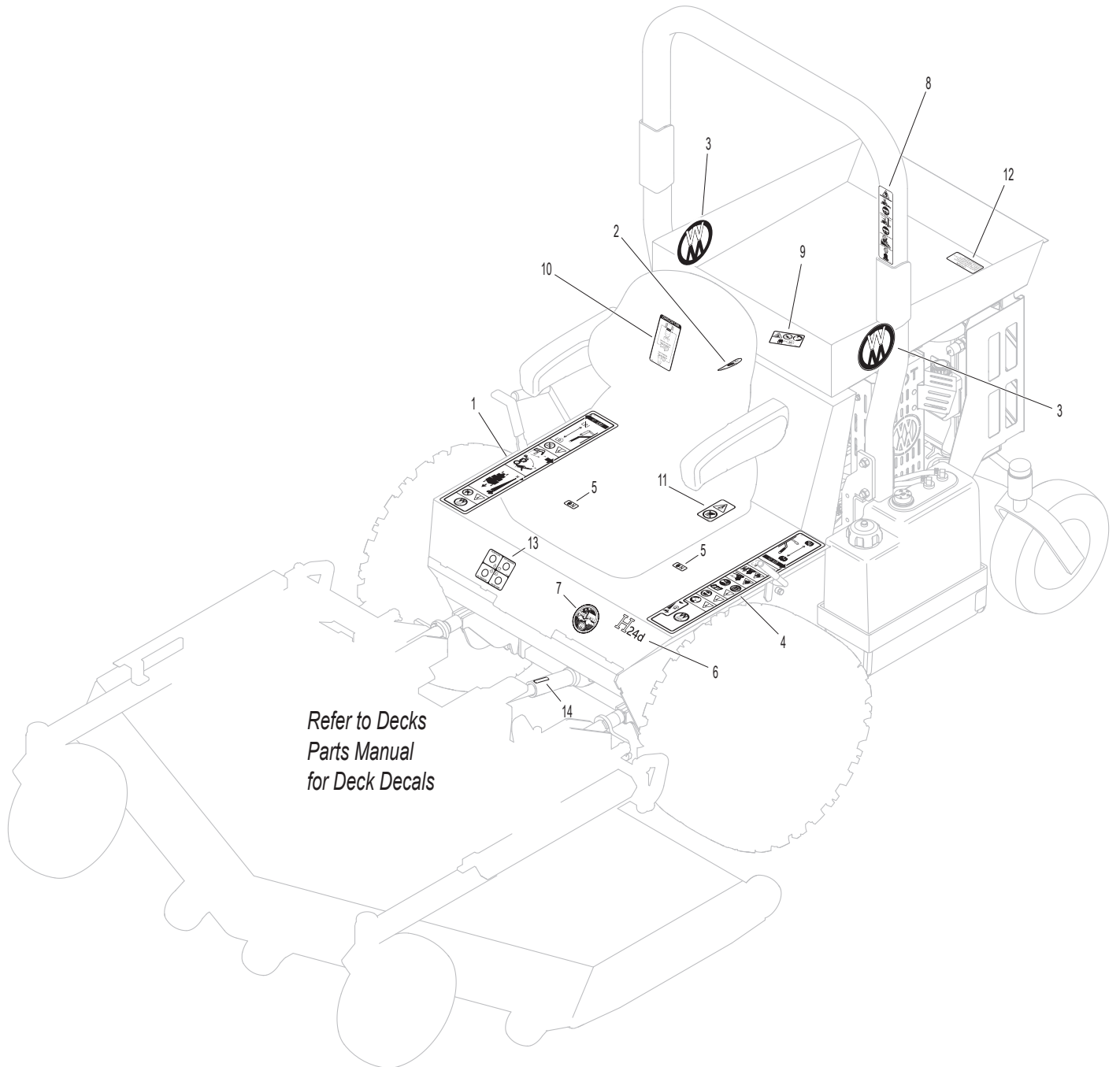

BODY ASSEMBLY

ITEM NO.	PART NO.	DESCRIPTION	NO. REQ'D	ITEM NO.	PART NO.	DESCRIPTION	NO. REQ'D
Body & Seat Assembly				Fasteners			
1	6103-14	Suspension Seat	1	F004		1/4-20 Keps Nut	13
2	M112	Edge Molding (16-3/8")	1	F005		1/4-20 ESNA Nut	2
3	8650-12	Bed Liner (23-5/16 x 25-3/8)	1	F009		5/16-18 Whiz Locknut	20
4	2650-2	Utility Bed (Includes Items # 2 & 3)	1	F020		5/16-18 ESNA Nut	3
5	7145	Gas Spring Assembly (Includes Items # 6 & 7)	1	F023		10-24 ESNA Nut	5
6	7147	Spring Clip	2	F029		1/4-20 x 1/2 Hex Bolt	4
7	7146	13mm Ball Stud	2	F035		5/16-18 x 1-1/4 Hex Bolt	2
8	7845-1	Rubber Bumper (1.375 x .750)	2	F049		5/16 SAE Washer	6
9	2105-13	Front Bed Support	1	F060		AN960516 Washer	2
10	5989-3	Dome Plug (5/16)	2	F084		5/16 Wave Spring Washer	2
11	5989-4	Dome Plug (3/8)	2	F091		5/16-18 x 5/8 Hex Bolt	4
12	7844	Rubber Bumper (1.25 x .250)	2	F093		5/16-18 x 1 Hex Bolt	1
13	5146	10mm Ball Stud	2	F226		5/16-18 x 7/8 Hex Bolt	4
14	2145	Gas Spring	1	F236		1/4-20 x 1-3/4 Hex Bolt	2
15	5180	Edge Molding, Lever Opening	2	F246		1/4-20 x 1/2 PTHMS	4
16	2504-4	Hinge (22.5)	1	F341		Coil Roll Pin (7/64 x 9/16)	1
17	2100-9	Front Body	1	F342		5/16 Conical Washer	2
18	5989-55	Dome Plug (1/2)	1	F442		1/4-20 x 5/8 PTHMS	5
19	7222	Extension Spring (1/4 x 3)	1	F613		10-24 x 1/2 Truss Head Torx	5
20	2383	Body Latch Hook	1	* Complete Tilt-Up Latch Assembly Kit available by ordering kit # 5744-5.			
21	7854	Plastic Tip, Red	1				
22	6103-44	Grammer Seat Mount Channel, RH	1				
23	6103-45	Grammer Seat Mount Channel, LH	1				
24	4102-1	Body Guide, Upper	1				
Tilt-Up Latch Assembly*							
25	5847	Plastic Tip	1				
26	5744-20	Spring Arm, Tilt-Up Latch	1				
27	5744-10	Spring Pivot Bushing	1				
28	5744-15	Compression Spring (3/8 x 5/8)	1				
29	5744-13	Mount Angle, LH	1				
30	5744-12	Hook, Tilt-Up Latch	1				
31	5744-14	Mount Angle, RH	1				

BODY ASSEMBLY

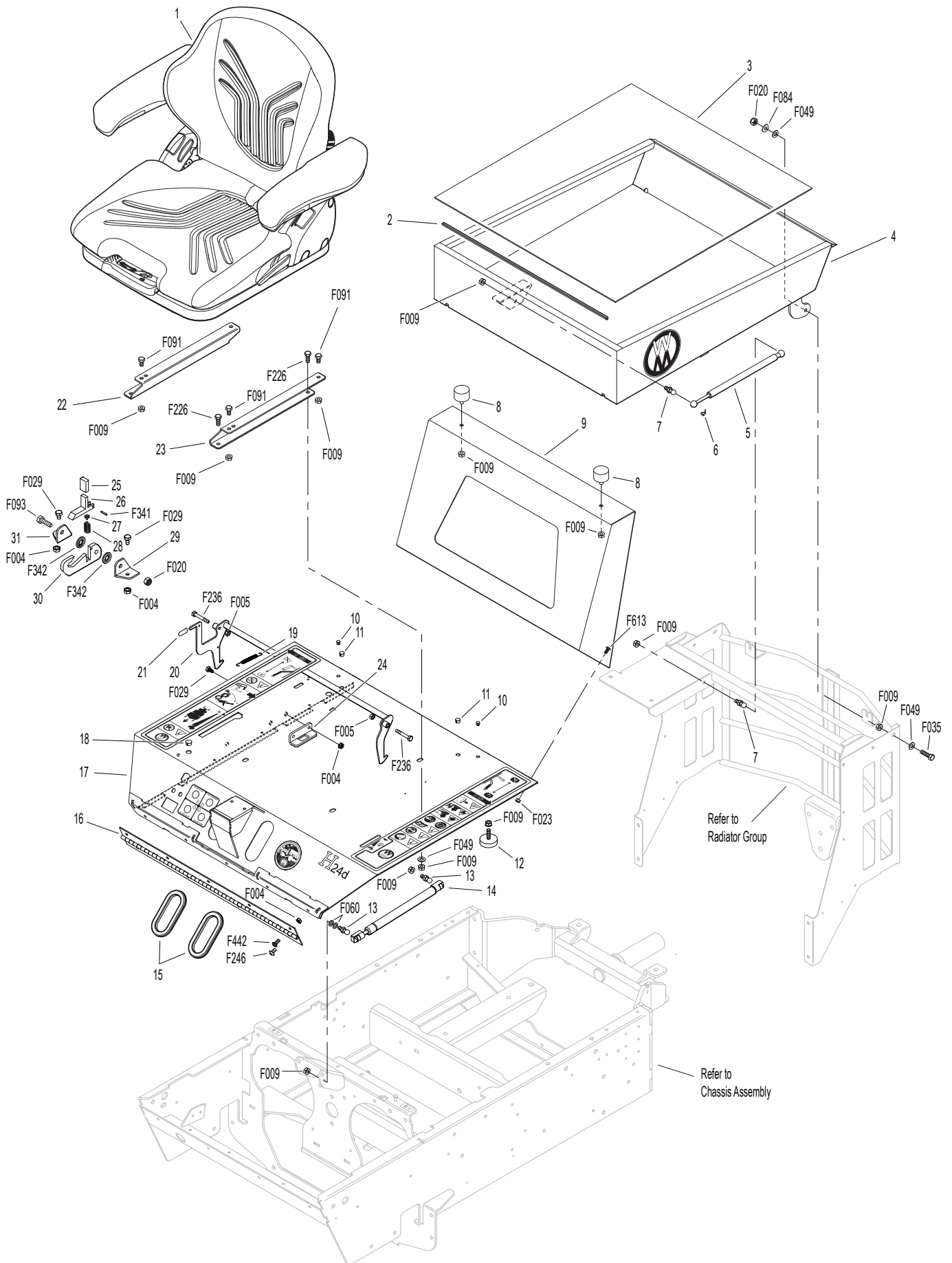

Model H24d Beginning S/N 190455
 Use only genuine Walker® replacement parts.

CHASSIS ASSEMBLY

ITEM NO.	PART NO.	DESCRIPTION	NO. REQ'D	ITEM NO.	PART NO.	DESCRIPTION	NO. REQ'D
Chassis Assembly				Deck Support Arm & Hitch Assemblies			
1	2325-8	Belt Guide	1	24	2300-9	Deck Arm Support Mount	1
2	2046-1	Gas Tank Mount, LH	1	25	6840-1	Support Arm Bushing (2-1/16)	2
3	2301-15	Debris Guard	1	26	2775	Lynch Pin (5/16 x 1-1/4)	2
4	2301-16	Back-Up Plate	1	27	5830-1	5/16-24 4" Grease Fitting	2
5	2300-14	Chassis Frame	1	28	2431-2	Deck Support Arm, LH (Includes Item # 27)	1
6	2046	Gas Tank Mount	1	29	2430-2	Deck Support Arm, RH (Includes Item # 27)	1
7	4102-2	Body Guide, Lower	1	Fasteners			
Tail Wheel Assembly					F004	1/4-20 Keps Nut	2
8	5830	Grease Fitting	2	F005	1/4-20 ESNA Nut	4	
9	2300-10	Tail Wheel Pivot (Includes Items # 8, 11, 12 & 15)	1	F009	5/16-18 Whiz Locknut	8	
10	2201-2	Fiberglide Thrust Washer	2	F031	1/4-20 x 5/8 Hex Bolt	2	
11	2201-3	Fiberglide Bearing (1-5/8)	2	F034	5/16-18 x 3/4 Hex Bolt	4	
12	5830-4	Grease Fitting (90 Deg.)	1	F093	5/16-18 x 1 Hex Bolt	4	
13	8769-8	Dust Cap, Deck Caster	2	F211	1/4-20 x 7/8 Hex Bolt	4	
14	8769-6	Bearing Cone (1" ID)	4	F218	7/16 Split Lock Washer	5	
15	8769-5	Bearing Cup (2 x 1-5/8)	4	F219	7/16-14 x 1-1/4 Hex Bolt	5	
16	8769-7	Seal	2	F256	7/16 SAE Washer	1	
17	2770	Caster Wheel Fork	2	F344	3/4-16 Slotted Hex Nut	2	
18	8039	Nut, Wheel Axle	2	F348	1/8 x 1-1/2 Cotter Pin	2	
19	8038-1	Spacer, Wheel Axle (.750 ID x 1.125 OD)	2	F430	7/16-20 ESNA Nut	2	
20	8768-2	Seal, Reverse Lip	4	F446	7/16-20 x 3-1/2 Grd 8 Bolt	2	
21	8037	Bearing Cone (3/4 ID)	4	F477	1/4-20 x 5/8 Carriage Bolt	2	
22	8035-1	Wheel & Tire (13 x 4.50-6) (W/Bearing Race)	2	F639	Belleville Washer (1.5 x .755 x .072)	2	
	8035-3	Tail Wheel Tire (13 x 4.5-6 Ply)	*	F718	5/16-18 x 5/16 Set Screw (Knurl Point)	2	
23	7038	Wheel Axle (3/4 x 5-9/16)	2	* Service Part Only			

CHASSIS ASSEMBLY

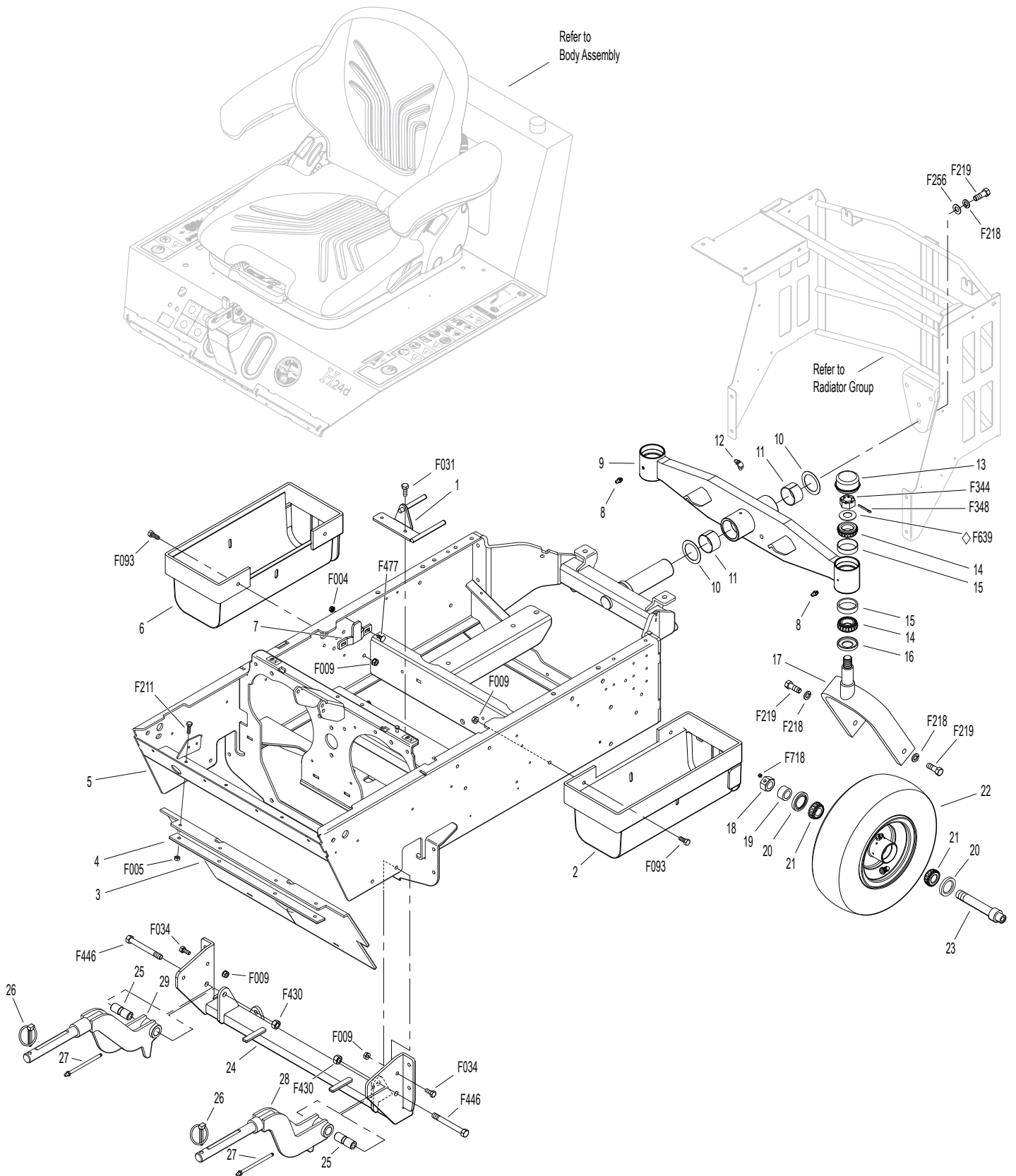

Model H24d Beginning S/N 190455
 Use only genuine **Walker**® replacement parts.

◇ Refer to CASTER WHEEL FORK INSTALLATION, Page 24.

MAIN COMPONENT POWER TRANSMISSION

ITEM NO.	PART NO.	DESCRIPTION	NO. REQ'D	ITEM NO.	PART NO.	DESCRIPTION	NO. REQ'D
PTO Drive Assembly				Fasteners			
1	4850	Handle Grip, Black	1	F004		1/4-20 Keps Nut	4
2	2358-1	Clutch Lever, MBS (Includes Items # 1 & 3)	1	F008		5/16-24 Keps Nut	1
3	5830-3	Grease Fitting (45 Deg.)	3	F009		5/16-18 Whiz Locknut	14
4	4303-7	Clutch Actuator Bolt (5/16)	1	F010		5/16-24 ESNA Nut	1
5	2306-2	Oilite Flanged Bushing	2	F012		3/8-16 Keps Nut	1
6	5830	Grease Fitting	2	F013		3/8-16 Whiz Locknut	3
7	2325-7	Clutch Arm (Includes Items # 5 & 6)	1	F019		1/4-20 ESNA Wing Nut	1
8	5221-1	Extension Spring (3/4 x 5)	1	F020		5/16-18 ESNA Nut	1
9	2358-11	Clutch Actuator	1	F029		1/4-20 x 1/2 Hex Bolt	1
10	5214-13	Ball Joint (3/8)	2	F031		1/4-20 x 5/8 Hex Bolt	5
11	2011-12	Flex Coupling Guard	1	F034		5/16-18 x 3/4 Hex Bolt	9
12	2358-9	Clutch Pivot Base	1	F035		5/16-18 x 1-1/4 Hex Bolt	2
13	2358-8	Adjustor Brace	1	F039		3/8-16 x 1-1/4 Hex Bolt	1
14	2302-16	Right Hand Shoe	1	F051		3/8 SAE Washer	2
15	2302-3	Left Hand Shoe	1	F060		AN960516 Washer	2
16	7775-6	Wire Lock Pin (2-1/2")	1	F061		1/4 Star Lock Washer	1
17	2349-17	Bearing Mount	1	F069		3/32 x 1/2 Cotter Pin	1
18	2406-5	Spacer	1	F091		5/16-18 x 5/8 Hex Bolt	1
19	2236-5	PTO Pulley (4.5/AAA)	1	F104		1/4-20 x 3/4 PFH Bolt	1
20	2359-1	Brake Band / Guard Mount	1	F120		AN960416 Washer	3
21	7775-8	Wire Lock Pin (4")	1	F146		1/4-20 Jam Nut	1
22	2302-5	PTO Shoe	1	F149		1/4 x 1/4 x 1-1/2 Key	1
23	7275-16	Universal Joint Tube Assembly / Spline	1	F168		5/16 Split Lock Washer	1
24	2274-10	PTO Drive Shaft Assembly	*	F170		5/16 x 1 x 7/64 Flat Washer (Zinc Plate)	1
25	2302-6	Shoe Mount, LH	1	F178		1/4 x 1 Fender Washer	1
26	2302-17	Upper Shoe, LH	1	F182		1/4 x 5/8 x 1/8 Washer	3
27	2358-7	Clutch / Pivot Stop	1	F183		.312 x .700 x .074 Washer	4
28	7523-2	Clevis Pin W/Hole (1/4 x 5/8)	1	F211		1/4-20 x 7/8 Hex Bolt	1
29	4359-2	Brake Band Link, Rear	1	F217		7/16-14 Hex Nut	2
30	8304	Brake Band (14-1/2)	1	F218		7/16 Split Lock Washer	2
31	4359-1	Brake Band Link, Front	1	F219		7/16-14 x 1-1/4 Hex Bolt	2
32	2410-2	Drive Shaft	1	F241		.375 x .875 x .10 Washer	1
33	2265	Bearing (20mm)	4	F255		5/16-18 x 1-1/2 Hex Bolt	4
34	2406-7	Pivot Shaft Spacer	1	F298		3/8-24 Jam Nut	2
35	2236-1	Idler Pulley (4.5/AAA)	2	F350		1/4-20 LP Nylock	5
36	2230	Engine PTO Belt / Set (3)	1	F389		3/8-16 x 2-3/4 Hex Bolt	1
37	2236-6	Pulley (Includes Items # F149 & F718)	1	F431		1/4-20 x 3-1/2 Hex Bolt	1
38	2236-4	Idler Pulley Shaft	1	F435		1/4 x 1/4 x 1-1/4 Key	2
39	7201-3	Fiberglide Bearing	2	F450		Washer 5/8 x 1-3/4 x 1/4	1
40	7201-9	Inner Race (5.324)	1	F452		5/8-18 Nylon Locknut	1
41	2359-3	Clutch Idler Arm (Includes Items # 3 & 39)	1	F473		5/16-18 x 5 Hex Bolt	1
42	2349-6	Flanged Bearing	1	F476		3/8-16 x 6-1/2 Hex Bolt	1
43	2358-12	Fiberglide Bushing	1	F477		1/4-20 x 5/8 Carriage Bolt	1
44	7201-2	Fiberglide Bearing 1/2"	1	F484		Washer .380 ID x 1.0 OD x .120	2
45	7377	Plastic Washer (1 x .438 x .025)	2	F551		5/16-18 Flange Top Lock Nut	4
46	7378	Pivot Bearing (7/16 x 9/16)	1	F576		3/8-16 ESNA Wing Nut	1
47	5214-2	Ball Joint (5/16-24) (Nylon Lined)	1	F581		1/4-20 x 1-1/4" Carriage Bolt	1
48	7226	Compression Spring (3/4 x 2-1/2)	1	F642		1/4 x .042 Belleville Washer	2
49	7380	Knuckle Joint	1	F651		5/16-18 x 5/8 Carriage Bolt Grd 2	4
				F718		5/16-18 x 5/16 Set Screw (Knurl Point)	1

* Service Part Only

ENGINE GROUP

ITEM NO.	PART NO.	DESCRIPTION	NO. REQ'D	ITEM NO.	PART NO.	DESCRIPTION	NO. REQ'D
Precleaner Assembly				47	NS	Fuel Line (Kohler)	1
1	4090-2	Air Cleaner Cap	*	48	M246	Fuel Line (1/4 x 20")	1***
2	5090-2	Vacuator Valve	1	49	M246	Fuel Line (1/4 x 5")	1***
3	5088-5	Air Cleaner Draw Latch	2	50	2010-6	Fuel Valve	1
4	5090-8	Air Cleaner Cartridge	1	51	M246	Fuel Line (1/4 x 39")	1***
5	5090-7	Safety Filter Insert	1	52	M246	Fuel Line (1/4 x 39-1/2")	1***
6	5088-4	Air Cleaner Band	1	53	2010-2	Fuel Transfer Mount	1
7	4090-1	Air Cleaner Assembly (Includes Items # 1-5)	1	54	M246	Fuel Line (1/4 x 11")	1***
8	5091-4	Indicator Nipple	1	Throttle Assembly			
9	5091-3	Air Flow Indicator	1	55	2108-6	Control Cable (73")	1
10	6029	Hose Clamp (1-13/16 to 2-3/4)	2	56	5108-1	Control Lever, Throttle / Choke	1
11	2012-5	Air Intake Hose	1	57	5108-5	Throttle Control Knob, Red	1
Engine Assembly				58	5108-11	Friction Washer (.062)	1
12	NS	Bolt (Kohler)	2	59	2108-1	Throttle Control and Cable Assembly (Includes Items # 55-58, 60-63, F002, F005, F050, F164 & F642)	1
13	2437-3	Upper Engine Brace	1	60	5108-9	Control Bracket	1
14	NS	Oil Filter	1**	61	5108-10	Friction Washer (.125)	1
15	2437-4	Engine Muffler Link	1	62	5108-7	Control Lock Tab	1
16	2013-2	Muffler	1	63	5172	Bearing, Delrin (.250 ID x .375 OD x .250)	1
17	2013-13	Muffler Shield	1	Fasteners			
18	NS	Nut (Kohler)	2	F002	10-24 Keps Nut		3
19	NS	Gasket (Kohler)	1	F004	1/4-20 Keps Nut		2
20	2437-1	Engine Mount, LH	1	F005	1/4-20 ESNA Nut		1
21	7440-9	Motor Mount	4	F009	5/16-18 Whiz Locknut		6
22	2437-2	Engine Mount, RH	1	F012	3/8-16 Keps Nut		8
23	NS	23.7 HP Engine (Kohler)	1	F013	3/8-16 Whiz Locknut		2
Fuel Tank Assembly				F013	3/8-16 Whiz Locknut		2
24	8055-4	Fuel Tank, 4.7 Gallon, Diesel (Black) (Includes Items # 26-31)	2	F025	10-24 x 3/8 PPHMS		2
25	7082-1	Fuel Tank Cap, Diesel	2	F031	1/4-20 x 5/8 Hex Bolt		2
26	5020-2	Fuel Filter, In Tank	2	F034	5/16-18 x 3/4 Hex Bolt		4
27	5086-7	Hose (1/4 x 6)	2	F038	3/8-16 x 1 Hex Bolt		2
28	5083-1	Bushing, Rubber	4	F050	1/4 SAE Washer		1
29	8055-2	Fuel Tank Gauge	2	F091	5/16-18 x 5/8 Hex Bolt		2
30	7046-1	Fuel Return Tube	2	F151	3/8-16 x 7/8 Hex Bolt		8
31	5083-8	Tank Tube (13")	2	F164	10-24 x 1/4 x 3/8 SHL Bolt		1
32	5879-3	Hose Clamp (1/2)	12	F184	1/4-20 x 1/2 Hex Bolt, SS		8
33	M246	Fuel Line (1/4 x 10")	1***	F185	1/4 Internal Star Lock Washer, SS		8
34	NS	Fuel Line (Kohler)	1	F198	.250 x .625 x .040 Washer, SS		4
35	NS	Fuel Line (Kohler)	1	F249	M10 Split Lock Washer		4
36	NS	Fuel Filter (Kohler)	1	F492	M12 Split Lock Washer		4
37	2437-5	Fuel Filter Mount	1	F493	M10-1.5 x 20 Hex Bolt		4
38	8043-10	1/4 x 3/16 Reducer Coupler	1	F494	M12-1.75 x 30 Hex Bolt		4
39	5879-4	Hose Clamp (7/16)	2	F642	1/4 x .042 Belleville Washer		1
40	M113	Fuel Line (3/16 x 4-1/2")	1***	* Service Part Only			
41	7840-7	Hose Clamp (13/16 to 1-3/4)	4	** Refer to the Operator's Manual for recommended part number.			
42	NS	Hose (Kohler)	1	*** Required hose specifications:			
43	NS	Crankcase Vacuum Regulator Valve (Kohler)	1	M113 - 3/16" ID fuel/oil/vapor hose (Gates 4219-0093 or equivalent)			
44	NS	Hose (Kohler)	1	M246 - 1/4" ID low permeation (<15g/m ² /day) fuel hose (Parker 38904 or equivalent)			
45	5975-1	Cable Tie (18# x 3-3/4")	4				
46	NS	Fuel Line (Kohler)	1				

RADIATOR GROUP

ITEM NO.	PART NO.	DESCRIPTION	NO. REQ'D	ITEM NO.	PART NO.	DESCRIPTION	NO. REQ'D
Radiator Assembly				Fasteners			
1	2427-5	Radiator	1	F002		10-24 Keps Nut	4
2	7427-21	Fan Mount Tab, LH	2	F004		1/4-20 Keps Nut	4
3	2425-3	Radiator Fan Shroud (Includes Item # F346)	1	F009		5/16-18 Whiz Locknut	12
4	7432	Shock Mount (1.0 OD x .75)	2	F025		10-24 x 3/8 PPHMS	4
5	7427-22	Fan Mount Tab, RH	2	F029		1/4-20 x 1/2 Hex Bolt	8
6	7429-6	Radiator Cooling Fan	*	F034		5/16-18 x 3/4 Hex Bolt	4
7	5841	Retainer Washer (3/8 x 1-1/4)	2	F061		1/4 Internal Star Lock Washer	8
8	7434	Washer (3/8 x 1-1/4 x 1/4)	4	F129		10-24 x 1/2 PTHMS	4
9	M204	Recovery Tank Hose (5/16 x 16-1/2")	1**	F360		1/4-20 x 3/8 Hex Bolt	4
10	2088-4	Air Cleaner Mount	1	F561		1/4 x 1-3/4 Fender Washer	2
11	5833	Cable Clamp (1/4)	1	* Service Part Only			
12	2427-6	Recovery Tank Mount	1	** Required hose specifications:			
13	2427-2	Recovery Tank Keeper	1	M204 - 5/16" ID 70 Durometer EPDM hose			
14	7427-18	Coolant Recovery Tank	1	M247 - 5/16" ID low permeation (<15g/m ² /day) fuel hose			
15	7440-5	Shock Mount (1-1/4 x 3/4)	2	(Parker 38905 or equivalent)			
16	2427	Radiator Mount	1				
17	7431-3	Radiator Channel Seal	2				
18	2425-2	Screen Channel	2				
19	7840-4	Hose Clamp (3/4 to 1-1/2)	4				
20	2012-3	Upper Radiator Hose	1				
21	7840-6	Hose Clamp (5/16 to 7/8)	2				
22	M247	Hose	1**				
23	2012-4	Lower Radiator Hose	1				
24	2425-1	Radiator Screen	1				
25	7429-7	Fan Blade Replacement	*				

HYDROSTATIC GROUND DRIVE ASSEMBLIES

ITEM NO.	PART NO.	DESCRIPTION	NO. REQ'D	ITEM NO.	PART NO.	DESCRIPTION	NO. REQ'D
Parking Brake Assembly				47	2025-41	Hydro-Gear ZT-3400, LH	1
1	2358-6	5/16-18 x 1-3/4 Stud	2	48	2026-41	Hydro-Gear ZT-3400, RH	1
2	2300-20	Parking Brake Hydro Mount, RH	1	Wheel Assembly			
3	5103-2	Pivot Bushing (5/16 ID)	2	49	2071-4	AT Wheel & Tire (23 x 10.50-12)	2
4	2406-3	Parking Brake Actuator Tube	1	PTO Coupler			
5	5222	Extension Spring (1/2 x 3-1/4)	1	50	2351-1	Rubber Iso Coupler	6
6	2280	Clevis (3/8)	1	51	2351-45	Flex Coupler Half	1
7	2406-4	Clevis Pin (5/16 x 1-1/8)	1	52	2351-19	Inner Flex Coupler Half	1
8	8655-4	Clevis Pin (5/16 x 3/4)	1	53	2351-50	Flex Coupler Half (1" Bore) (Includes Items # F718 & F435)	1
9	2406-14	Brake Actuator Pull	1	Fasteners			
10	4407-4	Bow Tie Cotter Pin	5	F002	10-24 Keps Nut		3
11	5830	Grease Fitting	1	F004	1/4-20 Keps Nut		2
12	7406-1	Handle Grip, Red	1	F005	1/4-20 ESNA Nut		2
13	2406-15	Parking Brake Lever / Idler Mount (Includes Items # 11 & 12)	1	F009	5/16-18 Whiz Locknut		17
14	2406-5	Spacer	1	F010	5/16-24 ESNA Nut		2
15	2300-1	Parking Brake Hydro Mount, LH	1	F012	3/8-16 Keps Nut		4
16	7523-2	Clevis Pin W/Hole (1/4 x 5/8)	2	F013	3/8-16 Whiz Locknut		7
17	2406-10	Parking Brake Rod	2	F015	1/2-20 Wheel Lug Nut		8
18	5665-1	Compression Spring (2-1/2)	2	F025	10-24 x 3/8 PPHMS		3
19	5463	Steering Lever Actuator	2	F029	1/4-20 x 1/2 Hex Bolt		1
Transaxle Reservoir Assemblies				F031	1/4-20 x 5/8 Hex Bolt		1
20	2025-17	Straight Thread Hose Fitting	2	F032	1/4-20 x 3/4 Hex Bolt		2
21	5879-4	Hose Clamp (7/16)	2	F034	5/16-18 x 3/4 Hex Bolt		16
22	M111	Hose (1/4 x 6-1/4")	2*	F035	5/16-18 x 1-1/4 Hex Bolt		1
23	5879-3	Hose Clamp (1/2)	4	F039	3/8-16 x 1-1/4 Hex Bolt		2
24	8043-9	1/4 x 1/4 x 1/4 Tee	1	F040	3/8-16 x 1-1/2 Hex Bolt		1
25	5832	Cable Clamp (1/2)	3	F042	3/8-16 x 2-1/4 Hex Bolt		1
26	2025-19	Hose Channel	1	F049	5/16 SAE Washer		1
27	M111	Hose (1/4 x 14-1/2")	1*	F050	1/4 SAE Washer		2
28	2024-1	Oil Expansion Reservoir (1 Qt.)	1	F051	3/8 SAE Washer		2
29	2025-21	Reservoir Bottle Mount	1	F052	5/16 Ext. Star Lock Washer		12
Ground Drive Assemblies				F108	3/8-16 x 2 Hex Bolt		1
30	2028-8	Lockout Arm, RH	1	F151	3/8-16 x 7/8 Hex Bolt		2
31	2248-1	Ground Drive Belt	1	F168	5/16 Split Lock Washer		4
32	4245	Idler Pulley (3/A)	2	F182	1/4 x 5/8 x 1/8 Washer		4
33	4349-12	Flange Bearing (1")	1	F183	.312 x .700 x .074 Washer		4
34	2240-2	Drive Pulley (Includes Item # F718)	1	F226	5/16-18 x 7/8 Hex Bolt		2
35	5841	Retainer Washer (3/8 x 1-1/4)	1	F231	1/4 x 3/4 Woodruff Key (#806)		1
36	5830-3	Grease Fitting (45 Deg.)	1	F336	3/8-16 Jam Nut		1
37	2349-14	Transmission Belt Tensioner (Includes Items # 36 & 38)	1	F350	1/4-20 LP Nylock		2
38	7201-3	Fiberglide Bearing	2	F388	3/8-16 x 2-1/2 Hex Bolt		4
39	7201-4	Inner Race (1-1/2)	1	F434	5/16-18 x 3-1/2 Hex Bolt		4
40	6325-3	Spacer Bushing (9/16)	1	F435	1/4 x 1/4 x 1-1/4 Key		1
41	5146	10mm Ball Stud	2	F481	Washer 5/16 x 1 x .125		12
42	2215-6	Pressure Dampener	1	F497	M8 x 20 Hex Bolt		4
43	2028-7	Lockout Arm, LH	1	F718	5/16-18 x 5/16 Set Screw (Knurl Point)		3
44	2026-6	Hydro-Gear® Oil Filter (52114)	2	* Required hose specifications:			
45	9430-1	Spacer Tube	4	M111 - 1/4" ID fuel/oil/vapor hose (Gates 4219-0103 or equivalent)			
46	2349-15	Idler Mount	1				

HYDROSTATIC GROUND DRIVE ASSEMBLIES

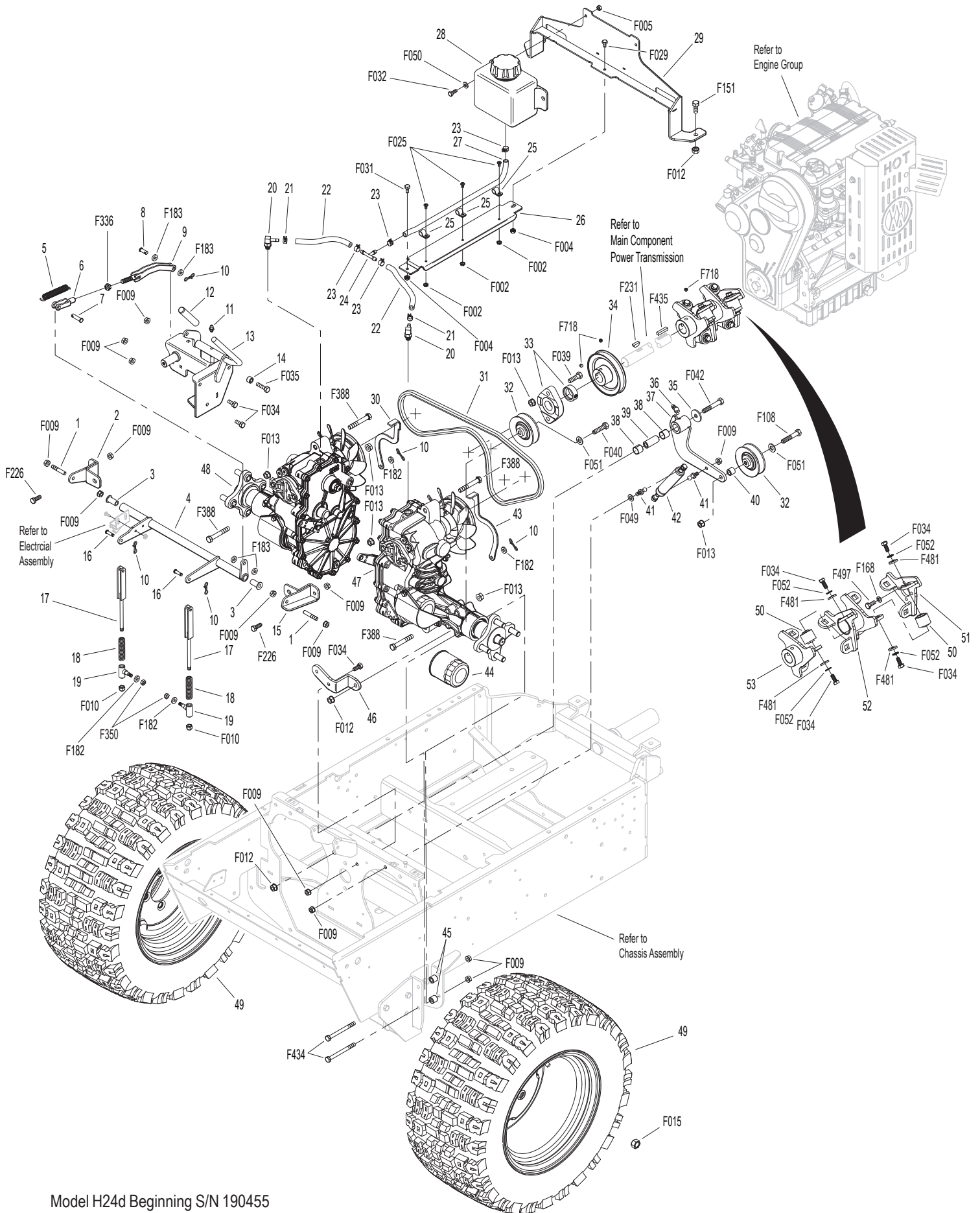

Model H24d Beginning S/N 190455
 Use only genuine Walker® replacement parts.

STEERING CONTROL ASSEMBLIES

ITEM NO.	PART NO.	DESCRIPTION	NO. REQ'D	ITEM NO.	PART NO.	DESCRIPTION	NO. REQ'D
Steering Lever & FSC Assemblies				33	4142-1	FSC Cam	1
1	5850-2	Handle Grip, Foam (5-1/2)	3	34	5141	FSC Friction Washer (1-1/2 x 3/8 x 1/16)	1
2	4170-4	FSC Lever Assembly (Includes Item # 3)	*	35	4142-2	FSC Friction Washer (1-1/2 x 1-1/32 x 1/16)	1
3	5830	Grease Fitting	1	36	9704-3	Pivot Rod Bushing, Plastic	2
4	7201-11	Inner Race (1.938)	1	37	2451-4	Steering Shaft Spacer	1
5	5214-4	Ball Joint (5/16-24) W/O Stud	2	Fasteners			
6	4213-3	Control Rod (6-1/4)	1	F004	1/4-20 Keps Nut	2	
7	5463-4	Steering Lever Actuator	2	F005	1/4-20 ESNA Nut	2	
8	5665-1	Compression Spring (2-1/2)	2	F008	5/16-24 Keps Nut	2	
9	2213	Control Rod (7")	2	F009	5/16-18 Whiz Locknut	6	
10	2212-3	Seal Retainer	2	F010	5/16-24 ESNA Nut	2	
11	2212	Transmission Control Arm Stop	2	F024	5/16-24 Jam Nut	4	
12	2212-2	Transmission Control Arm, RH	1	F035	5/16-18 x 1-1/4 Hex Bolt	1	
13	5214-2	Ball Joint (5/16-24) (Nylon Lined)	2	F044	5/16-24 x 3/4 Hex Bolt	2	
14	2212-1	Transmission Control Arm, LH	1	F050	1/4 SAE Washer	4	
15	2451-1	Steering Pivot Shaft With Stop	1	F060	AN960516 Washer	1	
16	5463-6	Washer 5/16 x 3/4 x .250	2	F093	5/16-18 x 1 Hex Bolt	2	
17	7201-2	Fiberglide Bearing (1/2")	2	F121	5/16-18 x 3/8 x 1 SHL Bolt	1	
18	5463-5	Steering Arm Pivot Bushing (SS)	2	F146	1/4-20 Jam Nut	2	
19	5830-3	Grease Fitting (45 Degree)	1	F167	5/16-18 Hex Nut	1	
20	8201-3	Fiberglide Bearing	4	F183	.312 x .700 x .074 Washer	6	
21	2451-7	Speed Control Actuator, LH (Includes Items # 19 & 20)	1	F188	1/4-20 Self-Locking Nut	4	
22	5146	10mm Ball Stud	4	F192	3/8-24 Self-Locking Nut	1	
23	4199-4	Steering Lever Dampener Assembly	2	F211	1/4-20 x 7/8 Hex Bolt	1	
24	2451-8	Speed Control Actuator, RH (Includes Items # 20 & 25)	1	F226	5/16-18 x 7/8 Hex Bolt	2	
25	5830-4	Grease Fitting (90 Deg.)	1	F235	5/16-18 x 2-1/2 Hex Bolt	1	
26	4451-4	FSC Friction Actuator	1	F385	1/4 x 1-1/4 Roll Pin	1	
27	4219	Extension Spring (3/4 x 6-1/2)	1	F390	1/4-20 x 7/8 Carriage Bolt	4	
28	5453-20	Steering Lever Handle (+1") Adjustable / SS (Includes Items # 1, F050, F188 & F390)	2	F391	1/4-20 x 1/2 Set Screw, SS	2	
29	4452-1	Steering Lever Tube W/Tab	2	F407	Belleville Washer 3/8 x 1.187, SS	1	
30	5450	D-Clip	2	F551	5/16-18 Flange Top Lock Nut	1	
31	5222	Extension Spring (1/2 x 3-1/4)	2	* Service Part Only			
32	4452-6	Steering Pivot (1/4-20 x 1-5/8)	2				

ROLL-OVER PROTECTION SYSTEM (ROPS)

ITEM NO.	PART NO.	DESCRIPTION	NO. REQ'D	ITEM NO.	PART NO.	DESCRIPTION	NO. REQ'D
ROPS Assembly				Fasteners			
1	A30	ROPS	1	F151		3/8-16 x 7/8 Hex Bolt	4
2	2302-11	Stop Plate	1	F306		3/8-16 x 3/4 Hex Bolt	4
3	2302-10	Threaded Knob	2	F399		1/2-13 x 3-1/4 Hex Bolt	5
4	2302-9	Hinge Pin	2	F565		1/2-13 x 3-1/4 Hex Bolt, Grade 8	1
5	2302-8	ROPS Seat Belt, Grammer Seat	1	F566		1/2-13 Nut, HXCL Reversible Locking Nut	6
				F587		3/8-16 Top Lock Flange Nut, Grade G	8

ROLL-OVER PROTECTION SYSTEM (ROPS)

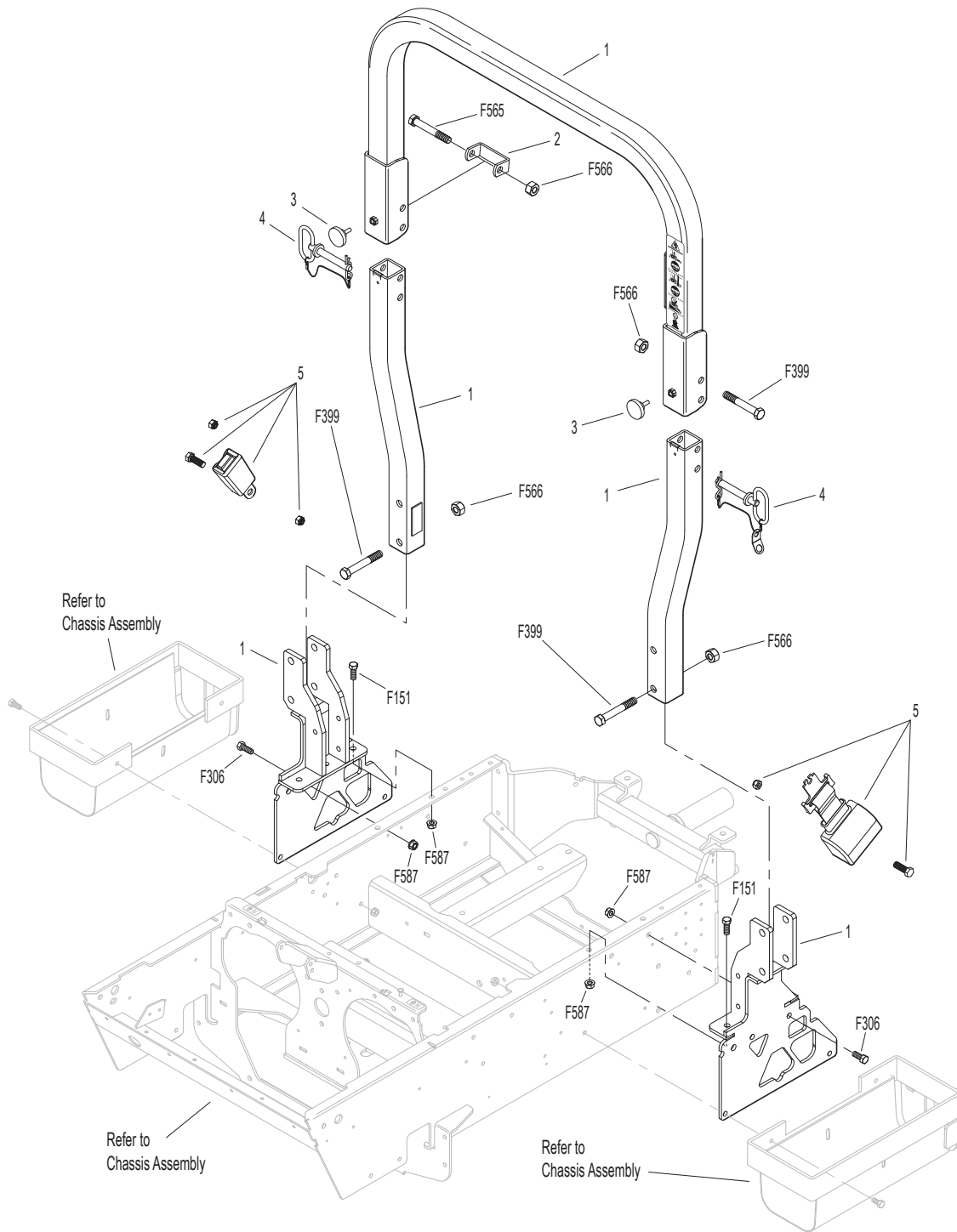

ELECTRICAL ASSEMBLY

ITEM NO.	PART NO.	DESCRIPTION	NO. REQ'D	ITEM NO.	PART NO.	DESCRIPTION	NO. REQ'D
Electrical Assembly				30	5942-4	Safety Switch (NO)	1
1	6105-3	Harness Clip	3	31	5942-5	Safety Switch (NO)	1
2	5977-3	Grommet (9/16)	1	32	8960-15	Ignition Switch W/Keys (Includes Items # 40, 41 & F349)	1
3	2103-8	Adapter Harness	1	33	8536-2	Warning Horn Assembly	1
4	7306-11	Switch (205 Deg. 3/8-18 NPT)	1	34	8996-9	Red Indicator Light Assembly	3
5	6941-9	Relay Switch 30/40 Amp	6	35	8990-1	Hourmeter (Global)	1
6	NS	Glow Plug Controller / Timer (Kohler)	1	36	8996-13	Glow Plug Light Assembly, Green	1
7	7948-6	Time Delay Module	1	37	7941-3	Boot, Circuit Breaker	2
8	7948-2	Time Delay Harness	1	38	7941-2	Circuit Breaker (10 Amp)	1
9	5941-2	Safety Switch	1	39	7941-5	Circuit Breaker (7 Amp)	1
10	8941	Circuit Breaker (30 Amp) (Auto Reset/Sealed)	2	40	7854	Plastic Tip, Red	1
11	8440-3	Jumper Wire	2	41	8960-3	Key Set W/Umbrella	1
12	7941	Circuit Breaker (40 Amp) (Auto Reset/Sealed)	1	Fasteners			
13	7433-2	Resistor, 50 Watt .4 OHM 1%	1	F002	10-24 Keps Nut		26
14	7433-3	Resistor Mount	1	F004	1/4-20 Keps Nut		3
15	NS	Regulator/Rectifier (Kohler)	1	F009	5/16-18 Whiz Locknut		3
16	2940-9	Ground Wire (8")	1	F019	1/4-20 ESNA Wing Nut		2
17	2940-3	Battery Cable, 14" (-)	1	F025	10-24 x 3/8 PPHMS		2
18	7428-2	Fan Control Module W/P Plug	1	F026	10-24 x 1/2 PPHMS		24
19	5975-1	Cable Tie (18# x 3-3/4")	2	F029	1/4-20 x 1/2 Hex Bolt		1
20	5932	Battery Terminal Insl., Blk (-)	1	F031	1/4-20 x 5/8 Hex Bolt		2
21	5910-6	Battery Spacer Pad	1	F034	5/16-18 x 3/4 Hex Bolt		3
22	7910-3	Battery (12V/350A CCA)	1	F050	1/4 SAE Washer		2
23	5839	Hook Bolt	2	F145	4-40 Keps Nut		2
24	5933	Battery Terminal Insl., Red (+)	1	F182	1/4 x 5/8 x 1/8 Washer		2
25	5844	Battery Hold-Down Bar	1	F232	10-32 Keps Nut		6
26	4940-6	Battery Cable, 33" (+)	1	F349	Washer .835 ID 1.122 OD, SS		1
27	2940-22	Wire Harness	1	F491	4-40 x 3/8 PPHMS		2
28	7833	Cable Clamp (7/8 x 1/4)	2				
29	5833	Cable Clamp (1/4)	1				

ELECTRICAL ASSEMBLY

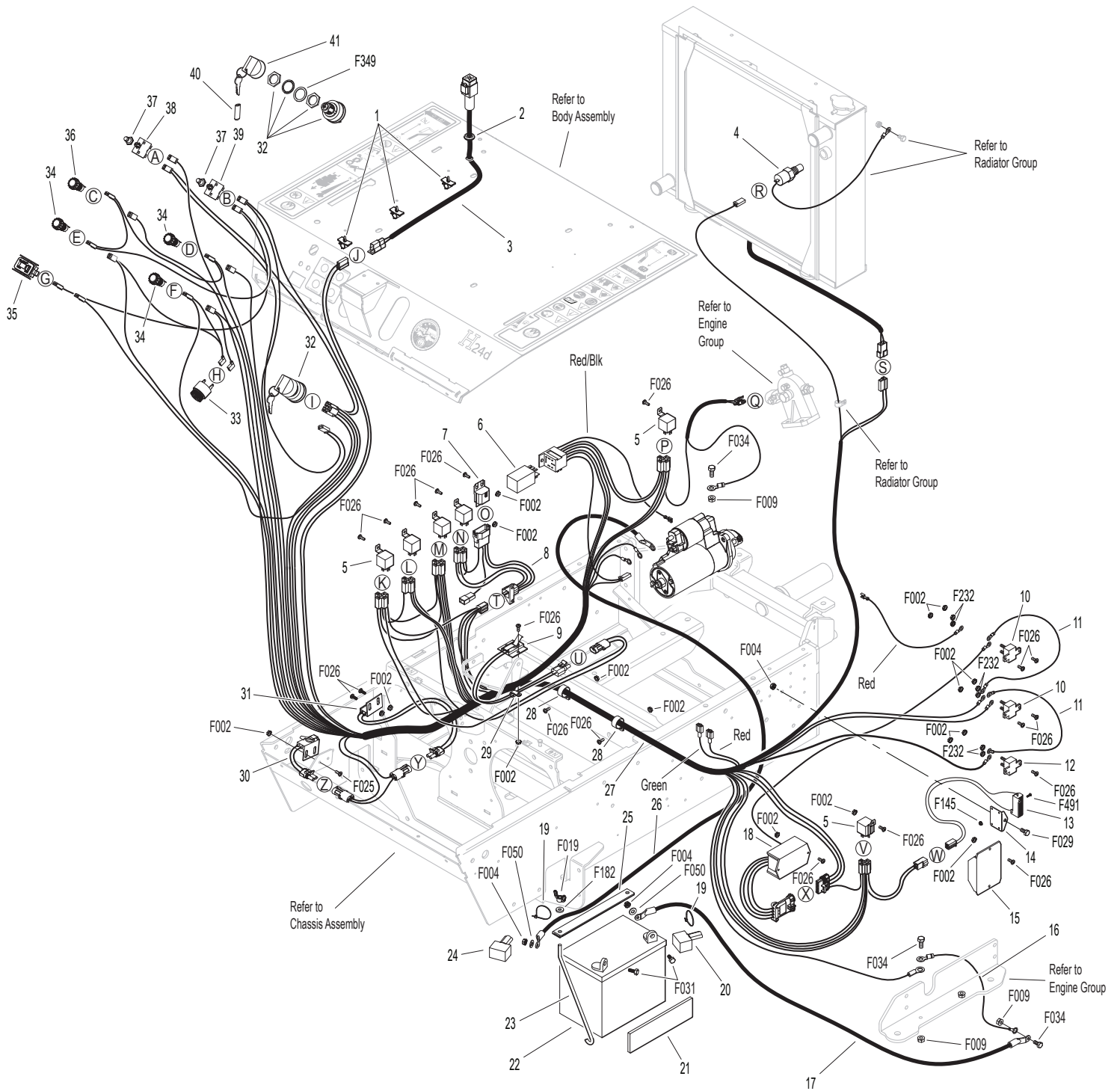

NOTE: Electrical connections are identified on page 26.

LUBRICATION POINTS

ITEM NO.	LOCATION	LUBRICATION TYPE	NO. PLACES	ITEM NO.	LOCATION	LUBRICATION TYPE	NO. PLACES
Lubrication Points							
1	Steering Lever Pivot	Grease	2	15	Rear Wheel Bearing	Grease	2
2	Deck Support Arm Pivot	Grease	2	16	Engine Oil Fill	Oil**	1
3	Deck-to-PTO Coupling (Grease Spline Slide Area)	Grease	1	17	PTO Belt Tightener Idler Pivot	Grease	1
4	Universal Joint Tube Assembly	Grease*	1	18	Clutch Actuator Push Rod	Grease	1
5	FSC Lever Pivot	Grease	1	19	Brake Band Pivot Pins (Clevis)	Oil	2
6	Body Latch Pivot	Oil	2	20	Parking Brake Lever Pivot	Grease	1
7	PTO Clutch Lever Pivot	Grease	1	21	Parking Brake Clevis	Oil	3
8	Clutch Arm Pivot	Grease	1	22	Throttle Control Pivot	Oil	1
9	Hydro Idler Arm Pivot	Grease	1				
10	Transaxle Oil Reservoir	Oil/20W-50	1	* Grease every 25 hours.			
11	Throttle Control Cable Ends	Oil	2	** Refer to H24d Operator's Manual for procedure for checking and changing oil in Engine Crankcase.			
12	Engine Dipstick	Oil**	1	NOTE: See Model H24d Operator's Manual (P/N 2000-47) for proper lubrication intervals.			
13	Tail Wheel Caster Fork Pivot	Grease	2				
14	Rear Axle Pivot	Grease	1				

LUBRICATION POINTS

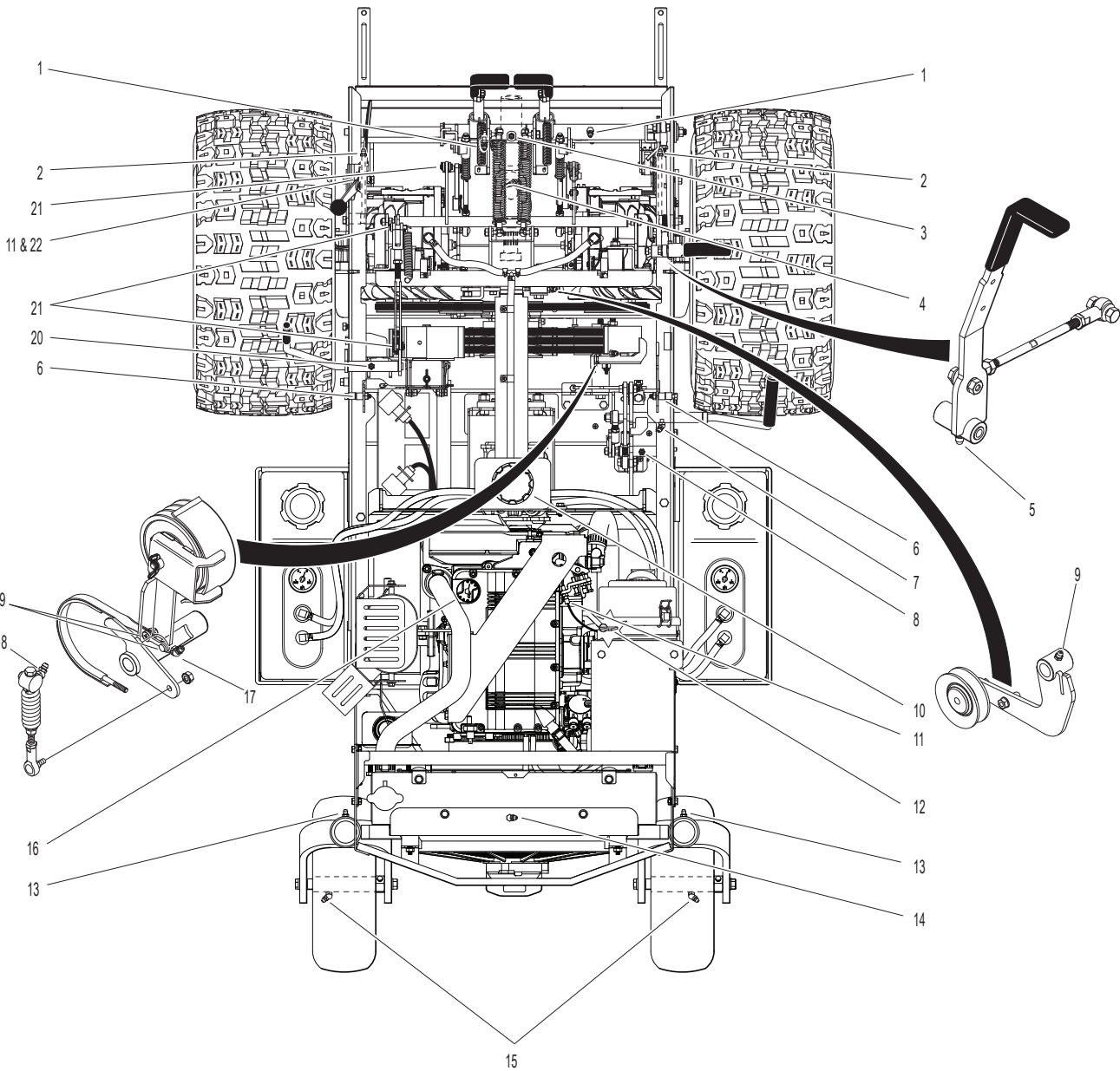

CASTER WHEEL FORK INSTALLATION

ITEM NO.	DESCRIPTION	ITEM NO.	DESCRIPTION
----------	-------------	----------	-------------

Caster Wheel Fork Assembly

- 1 Installing the Caster Fork with a Belleville Washer:
 - a. Install the fork up into the bearing housing through the lower and upper tapered roller bearings. Rotate the fork as the seal is engaging onto the shaft to prevent the seal lip from rolling.
 - b. Place a Belleville washer onto the fork shaft with the cupped side of the washer down against the bearing, and thread the slotted hex nut finger-tight onto the shaft.
 - c. Using a wrench or socket, tighten the slotted hex nut by hand only until the Belleville washer is fully compressed, which is felt as a distinct increase in the amount of force required to turn the nut.
 - d. Back the nut off one to two notches until the cotter pin hole is visible, and install the cotter pin to lock the nut in place.

NOTE: The tension of the compressed Belleville washer provides the correct amount of bearing pre-load and will remain consistent with use. Do not over-tighten the nut, which will bind the caster pivot and cause unnecessary turning friction.

Tail Wheel Pivot Assembly

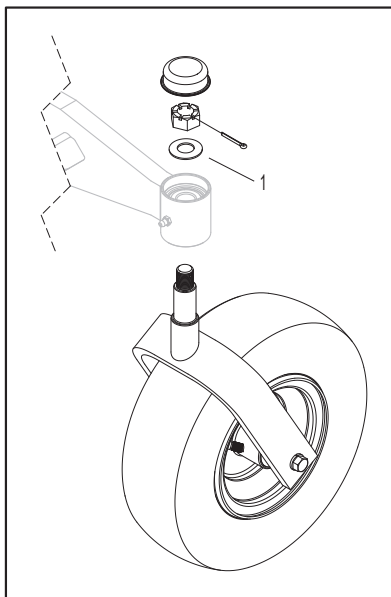

WIRING SCHEMATIC

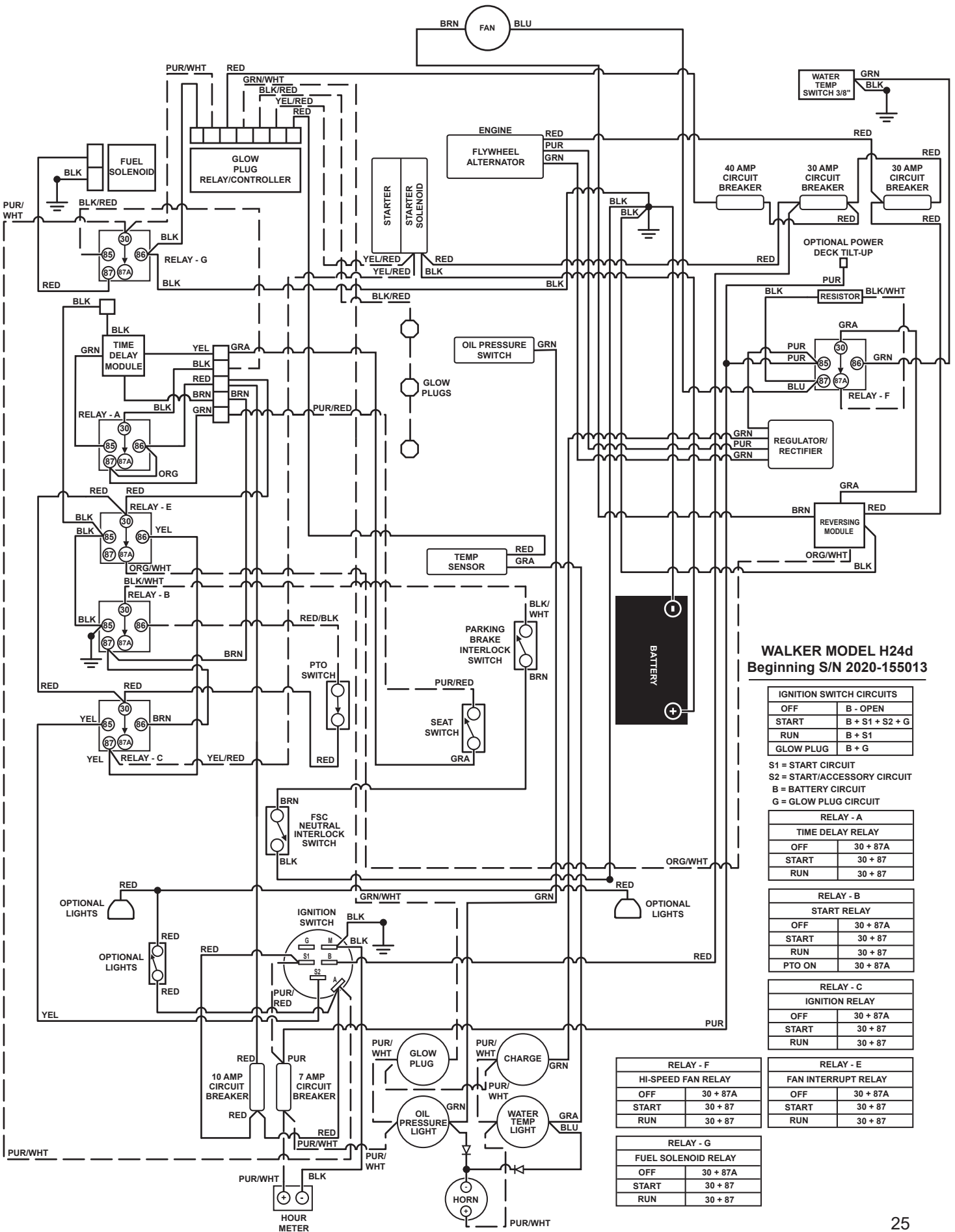

WALKER MODEL H24d Beginning S/N 2020-155013

IGNITION SWITCH CIRCUITS	
OFF	B - OPEN
START	B + S1 + S2 + G
RUN	B + S1
GLOW PLUG	B + G

S1 = START CIRCUIT
S2 = START/ACCESSORY CIRCUIT
B = BATTERY CIRCUIT
G = GLOW PLUG CIRCUIT

RELAY - A	
TIME DELAY RELAY	
OFF	30 + 87A
START	30 + 87
RUN	30 + 87

RELAY - B	
START RELAY	
OFF	30 + 87A
START	30 + 87
RUN	30 + 87
PTO ON	30 + 87A

RELAY - C	
IGNITION RELAY	
OFF	30 + 87A
START	30 + 87
RUN	30 + 87

RELAY - F	
HI-SPEED FAN RELAY	
OFF	30 + 87A
START	30 + 87
RUN	30 + 87

RELAY - E	
FAN INTERRUPT RELAY	
OFF	30 + 87A
START	30 + 87
RUN	30 + 87

RELAY - G	
FUEL SOLENOID RELAY	
OFF	30 + 87A
START	30 + 87
RUN	30 + 87

ELECTRICAL ASSEMBLY (CONNECTIONS)

DETAIL A



P/N-7942-4

DETAIL B



P/N-7942-4

DETAIL C



P/N-7942-4

DETAIL D



P/N-7942-4

DETAIL E



P/N-7942-4

DETAIL F



P/N-7942-4

DETAIL G



P/N-7942-4

DETAIL H

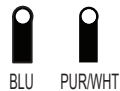

P/N-7996-2

DETAIL I

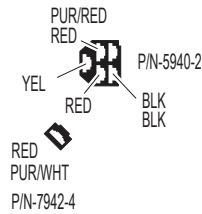

RED PUR/WHT
P/N-7942-4

DETAIL J



P/N-7942-10

DETAIL K



DETAIL L

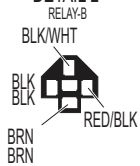

DETAIL M

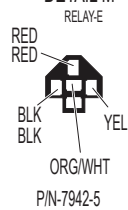

DETAIL N

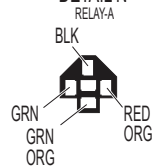

DETAIL O



DETAIL P

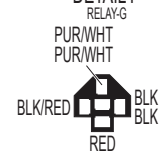

DETAIL Q



DETAIL R



DETAIL S



DETAIL T

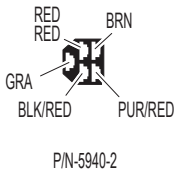

DETAIL U



DETAIL V



DETAIL W



DETAIL X

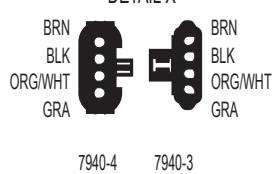

DETAIL Y



DETAIL Z

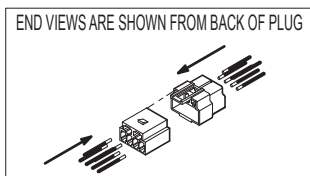

LIMITED WARRANTY FOR WALKER MODEL H24d RIDER MOWERS

1. WHAT THIS WARRANTY COVERS, AND FOR HOW LONG:

Walker Manufacturing company will, at its option, repair or replace, without charge, any part covered by this warranty which is found to be defective in material and/or workmanship within two (2) years* after date of sale to the original retail purchaser unless the product is used for rental purposes, in which case this warranty is limited to ninety (90) days. At Walker's request, customer will make the defective part available for inspection by Walker and/or return the defective part to Walker, transportation charges prepaid. All parts and components of the Walker Mower are covered by this warranty **except** the following components which are warranted separately by their respective manufacturers:

Kohler Engine

The available warranties covering these items are furnished with each mower. Walker does not assume any warranty obligation, liability or modification for these items, which are covered exclusively by the stated warranty of the respective manufacturers noted above.

The Fulbat battery comes with a one (1) year warranty from the date of sale to the original retail purchaser. Warranty claims for the battery are administered through Walker Manufacturing.

★ Extended warranties are offered for the following powertrain components:

- A three (3) year or 3000 hour (whichever comes first) warranty is offered for Hydro-Gear ZT-3400 hydrostatic transmissions; covers full cost of replacement up to 1000 hours of use, and after 1000 hours warranty coverage is prorated against 3000 hours.

2. WHAT THIS WARRANTY DOES NOT COVER:

- A. This warranty does not cover defects caused by depreciation or damage caused by normal wear, accidents, improper maintenance, improper use or abuse of the product, alterations, or failure to follow the instructions contained in the Owner's Manual for operation and maintenance.
- B. The customer shall pay any charges for making service calls and/or for transporting the mower to and from the place where the inspection and/or warranty work is performed.

3. HOW TO OBTAIN SERVICE UNDER THIS WARRANTY:

Warranty service can be arranged by contacting the dealer where you purchased the mower or by contacting Walker Manufacturing Company, 5925 East Harmony Road, Ft. Collins, CO 80528. Proof of the date of purchase may be required to verify warranty coverage.

4. WARRANTY LIMITATION:

- A. **THERE IS NO OTHER EXPRESS WARRANTY. ANY WARRANTY THAT MAY BE IMPLIED FROM THIS PURCHASE INCLUDING MERCHANTABILITY AND FITNESS FOR A PARTICULAR PURPOSE IS HEREBY LIMITED TO THE DURATION OF THIS WARRANTY AND TO THE EXTENT PERMITTED BY LAW ANY AND ALL IMPLIED WARRANTIES ARE EXCLUDED.** Some states do not allow limitations on how long an implied warranty lasts, so the above limitations may not apply to you.
- B. **WALKER WILL NOT BE LIABLE FOR ANY INCIDENTAL, CONSEQUENTIAL, OR SPECIAL DAMAGES AND/OR EXPENSES IN CONNECTION WITH THE PURCHASE OR USE OF THE MOWER.** Some states do not allow the exclusion or limitation of incidental or consequential damages, so the above limitation(s) or exclusion(s) may not apply to you.
- C. Only the warranty expressed in this limited warranty shall apply and no dealer, distributor, or individual is authorized to amend, modify, or extend this warranty in any way. Accordingly, additional statements such as dealer advertising or presentations, whether oral or written, do not constitute warranties by Walker, and should not be relied upon.
- D. This warranty gives you specific legal rights, and you may also have other rights which vary from state to state.

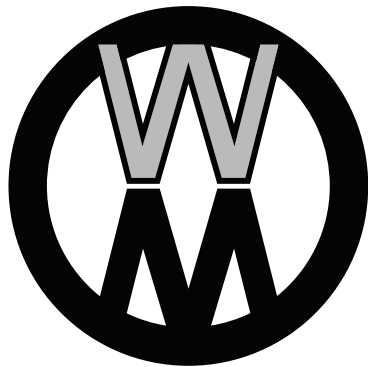

WALKER

WALKER MFG. CO. • 5925 E. HARMONY ROAD, FORT COLLINS, CO 80528 • (970) 221-5614
FORM NO. 011625 PRINTED IN USA www.walker.com ©2025 WALKER MFG. CO